

Results Comparison Versions W 7.4.14/ T 7.4.04 to W 7.4.06 / T 7.4.03

Whole Products

10/03/2015 -- calculated W 7.4.06 / T 7.4.03

Results are identical between the two versions

12/09/2016 -- calculated W 7.4.14 / T 7.4.04

Product Ref.	Product Type	Material: Frame / Spacer	Glazing System	Size		U (W/m2-K)				SHGC				VT				CR			
				Width (mm)	Height (mm)	W7.4.06 / T7.4.03	W7.4.14 / T7.4.04	diff (if >= 0.0005)	Diff %	W7.4.06 / T7.4.03	W7.4.14 / T7.4.04	diff	Diff %	W7.4.06 / T7.4.03	W7.4.14 / T7.4.04	diff	Diff %	W7.4.06 / T7.4.03	W7.4.14 / T7.4.04	diff	Diff %
Kawneer 1600 S1	Curtain Wall	TI AL / AL	Clr-6_Air-Clr-6	2032.0	2032.0	3.481479	3.481479	0.00000	0.00%	0.60098	0.600979	0.000	0.00%	0.66378	0.66378	0.000	0.00%	30.13632	30.136322	0.00000	0.0%
CW3	Curtain Wall	TI AL (e=0.2) / AL	Clr-6_Air-Clr-6	2032.0	2032.0	3.127849	3.127849	0.00000	0.00%	0.6074	0.607401	0.000	0.00%	0.67239	0.672392	0.000	0.00%	16.06694	16.066938	0.00000	0.0%
		TI AL (e=0.9) / AL		2032.0	2032.0	3.439269	3.439269	0.00000	0.00%	0.61019	0.61019	0.000	0.00%	0.67239	0.672392	0.000	0.00%	21.73728	21.737284	0.00000	0.0%
Fiberglass	Casement	Fiberglass / AL	Clr-6_Air-LowE2 72-6	600.0	1500.0	1.961189	1.961189	0.00000	0.00%	0.33804	0.338038	0.000	0.00%	0.48332	0.483322	0.000	0.00%	48.12446	48.124462	0.00000	0.0%
PFM	Casement	Wood / AL	Clr-5-Air-Clr-5	914.4	1219.2	2.683719	2.683719	0.00000	0.00%	0.62917	0.629168	0.000	0.00%	0.682	0.682002	0.000	0.00%	39.73116	39.731155	0.00000	0.0%
			Lowe179-5 Air Clr5	914.4	1219.2	2.017673	2.017673	0.00000	0.00%	0.52997	0.529966	0.000	0.00%	0.65409	0.654087	0.000	0.00%	46.79863	46.798634	0.00000	0.0%
PVC	Casement	PVC / AL Swiggle	LowE_037-Air-Clr	609.6	1219.2	1.789399	1.789399	0.00000	0.00%	0.25483	0.254834	0.000	0.00%	0.38176	0.38176	0.000	0.00%	56.53935	56.539352	0.00000	0.0%
Velux - FS87	Skylight	AL Clad Wood / SST	Lowe270-3 Ar Clr-3	547.9	1314.4	3.093089	3.093089	0.00000	0.00%	0.35236	0.352362	0.000	0.00%	0.66532	0.665323	0.000	0.00%	48.81619	48.816185	0.00000	0.0%
TRR01	Fixed	TB AL / AL	CmftE2-3_Air_HMSC 75_Air_Cmft E2-3	1016.0	1016.0	1.893416	1.893416	0.00000	0.00%	0.27523	0.275227	0.000	0.00%	0.4144	0.414402	0.000	0.00%	40.43936	40.439362	0.00000	0.0%
TRR97	Fixed	AL Clad Wood / Galv. Steel	LowE272-5_Air-Clr-5	1219.2	1219.2	1.952107	1.952107	0.00000	0.00%	0.34645	0.346445	0.000	0.00%	0.59606	0.596056	0.000	0.00%	47.15976	47.159756	0.00000	0.0%
TRR99	Hor. Slider	AL / Galv. Steel	Clr-3_Air_HMSC 75_Air_S500 CL-3	1524.0	914.4	2.760726	2.760726	0.00000	0.00%	0.31497	0.314971	0.000	0.00%	0.4999	0.499897	0.000	0.00%	14.55842	14.558422	n/a	n/a
Max Diff								0.00000	0.00%					0.000	0.00%					0.00000	0.00%

Results Comparison THERM Version 7.4.04 to 7.4.03

Frames

NOTE: Glazing systems recalculated, frame files calculated using BC condition #2

Results are identical between the two versions

10/03/2015 -- ran W7.4.06 / T 7.4.03

12/09/2016 -- ran W7.4.14 / T 7.4.04

ID	Name	W7.4.06-T7.4.03					W7.4.14-T7.4.04					Uval (W/m2K)		U_edge (W/m2K)		Pfd		Ucenter (W/m2K)		
		Uval	U_edge	Pfd	Ucenter	Abs	Uval	U_edge	Pfd	Ucenter	Abs	DIFF	Diff (%)	DIFF	Diff (%)	DIFF	Diff (%)	DIFF	Diff (%)	
11	1600S1_hd.thm	7.227078	2.861175	67.361816	2.689528	0.3	11	7.227078	2.861175	67.361816	2.689528	0.3	0.000	0.00%	0.00000	0.00%	0.00000	0.00%	0.00000	0.00%
12	1600S1_jb.thm	7.217207	2.858271	67.361328	2.689528	0.3	12	7.217207	2.858271	67.361328	2.689528	0.3	0.000	0.00%	0.00000	0.00%	0.00000	0.00%	0.00000	0.00%
13	1600S1_mr.thm	9.803758	2.792631	71.24585	2.689528	0.3	13	9.803758	2.792631	71.24585	2.689528	0.3	0.000	0.00%	0.00000	0.00%	0.00000	0.00%	0.00000	0.00%
14	1600S1_si.thm	7.206437	2.860169	67.361328	2.689528	0.3	14	7.206437	2.860169	67.361328	2.689528	0.3	0.000	0.00%	0.00000	0.00%	0.00000	0.00%	0.00000	0.00%
21	CW3_hd_02.thm	5.25582	3.092388	59.556183	2.681182	0.3	21	5.25582	3.092388	59.556183	2.681182	0.3	0.000	0.00%	0.00000	0.00%	0.00000	0.00%	0.00000	0.00%
22	CW3_jb_02.thm	5.244606	3.090606	59.55603	2.681182	0.3	22	5.244606	3.090606	59.55603	2.681182	0.3	0.000	0.00%	0.00000	0.00%	0.00000	0.00%	0.00000	0.00%
23	CW3_mr_02.thm	6.938507	3.084737	68.312256	2.681182	0.3	23	6.938507	3.084737	68.312256	2.681182	0.3	0.000	0.00%	0.00000	0.00%	0.00000	0.00%	0.00000	0.00%
24	CW3_si_02.thm	5.267759	3.097396	57.777527	2.681182	0.3	24	5.267759	3.097396	57.777527	2.681182	0.3	0.000	0.00%	0.00000	0.00%	0.00000	0.00%	0.00000	0.00%
25	CW3_hd_09.thm	7.518789	2.900505	59.556183	2.681182	0.3	25	7.518789	2.900505	59.556183	2.681182	0.3	0.000	0.00%	0.00000	0.00%	0.00000	0.00%	0.00000	0.00%
26	CW3_jb_09.thm	7.514257	2.906071	59.55603	2.681182	0.3	26	7.514257	2.906071	59.55603	2.681182	0.3	0.000	0.00%	0.00000	0.00%	0.00000	0.00%	0.00000	0.00%
27	CW3_mr_09.thm	9.571283	2.908318	68.312256	2.681182	0.3	27	9.571283	2.908318	68.312256	2.681182	0.3	0.000	0.00%	0.00000	0.00%	0.00000	0.00%	0.00000	0.00%
28	CW3_si_09.thm	7.627611	2.9064	57.777527	2.681182	0.3	28	7.627611	2.9064	57.777527	2.681182	0.3	0.000	0.00%	0.00000	0.00%	0.00000	0.00%	0.00000	0.00%
31	Fiberglass_hd.thm	2.115713	2.352837	70.637405	1.677865	0.3	31	2.115713	2.352837	70.637405	1.677865	0.3	0.000	0.00%	0.00000	0.00%	0.00000	0.00%	0.00000	0.00%
32	Fiberglass_jb.thm	2.095859	2.350737	70.63623	1.677865	0.3	32	2.095859	2.350737	70.63623	1.677865	0.3	0.000	0.00%	0.00000	0.00%	0.00000	0.00%	0.00000	0.00%
33	Fiberglass_si.thm	2.114017	2.352594	70.63623	1.677865	0.3	33	2.114017	2.352594	70.63623	1.677865	0.3	0.000	0.00%	0.00000	0.00%	0.00000	0.00%	0.00000	0.00%
41	PFM01_hd.thm	2.20664	3.012841	42.87616	2.714314	0.3	41	2.20664	3.012841	42.87616	2.714314	0.3	0.000	0.00%	0.00000	0.00%	0.00000	0.00%	0.00000	0.00%
42	PFM01_jb.thm	2.20444	3.013326	42.876221	2.714314	0.3	42	2.20444	3.013326	42.876221	2.714314	0.3	0.000	0.00%	0.00000	0.00%	0.00000	0.00%	0.00000	0.00%
43	PFM01_si.thm	2.20822	3.013447	42.876221	2.714314	0.3	43	2.20822	3.013447	42.876221	2.714314	0.3	0.000	0.00%	0.00000	0.00%	0.00000	0.00%	0.00000	0.00%
44	PFM02_hd.thm	2.183683	2.418898	42.87616	1.853738	0.3	44	2.183683	2.418898	42.87616	1.853738	0.3	0.000	0.00%	0.00000	0.00%	0.00000	0.00%	0.00000	0.00%
45	PFM02_jb.thm	2.181394	2.419342	42.876221	1.853738	0.3	45	2.181394	2.419342	42.876221	1.853738	0.3	0.000	0.00%	0.00000	0.00%	0.00000	0.00%	0.00000	0.00%
46	PFM02_si.thm	2.185318	2.419544	42.876221	1.853738	0.3	46	2.185318	2.419544	42.876221	1.853738	0.3	0.000	0.00%	0.00000	0.00%	0.00000	0.00%	0.00000	0.00%
51	PVC_hd.thm	1.760321	2.021321	72.357208	1.723422	0.3	51	1.760321	2.021321	72.357208	1.723423	0.3	0.000	0.00%	0.00000	0.00%	0.00000	0.00%	0.00000	0.00%
52	PVC_jb.thm	1.694587	2.042317	89.807007	1.723422	0.3	52	1.694587	2.042317	89.807007	1.723423	0.3	0.000	0.00%	0.00000	0.00%	0.00000	0.00%	0.00000	0.00%
53	PVC_si.thm	1.755217	2.020916	72.357193	1.723422	0.3	53	1.755217	2.020916	72.357193	1.723423	0.3	0.000	0.00%	0.00000	0.00%	0.00000	0.00%	0.00000	0.00%
61	FS95_hd_75_c_20.thm	24.373428	2.416143	8.60376	2.014867	0.3	61	24.37343	2.416143	8.60376	2.014867	0.3	0.000	0.00%	0.00000	0.00%	0.00000	0.00%	0.00000	0.00%
62	FS95_jb_75_c_20.thm	24.417957	2.415061	8.600586	2.014867	0.3	62	24.41796	2.415061	8.600586	2.014867	0.3	0.000	0.00%	0.00000	0.00%	0.00000	0.00%	0.00000	0.00%
63	FS95_si_75_c_20.thm	11.11496	2.129941	19.075211	2.014867	0.3	63	11.11496	2.129941	19.075211	2.014867	0.3	0.000	0.00%	0.00000	0.00%	0.00000	0.00%	0.00000	0.00%
71	TRR01_hd.thm	3.595428	1.75223	61.035721	1.265482	0.3	71	3.595428	1.75223	61.035721	1.265482	0.3	0.000	0.00%	0.00000	0.00%	0.00000	0.00%	0.00000	0.00%
72	TRR01_jb.thm	3.616319	1.752918	61.035828	1.265482	0.3	72	3.616319	1.752918	61.035828	1.265482	0.3	0.000	0.00%	0.00000	0.00%	0.00000	0.00%	0.00000	0.00%
73	TRR01_si.thm	3.594959	1.75215	61.035828	1.265482	0.3	73	3.594959	1.75215	61.035828	1.265482	0.3	0.000	0.00%	0.00000	0.00%	0.00000	0.00%	0.00000	0.00%
81	TRR97_hd.thm	2.500365	2.36067	50.013748	1.721165	0.3	81	2.500365	2.36067	50.013748	1.721165	0.3	0.000	0.00%	0.00000	0.00%	0.00000	0.00%	0.00000	0.00%
82	TRR97_jb.thm	2.499379	2.356269	50.013779	1.721165	0.3	82	2.499379	2.356269	50.013779	1.721165	0.3	0.000	0.00%	0.00000	0.00%	0.00000	0.00%	0.00000	0.00%
83	TRR97_si.thm	2.483977	2.352191	50.013779	1.721165	0.3	83	2.483977	2.352191	50.013779	1.721165	0.3	0.000	0.00%	0.00000	0.00%	0.00000	0.00%	0.00000	0.00%
91	TRR99_hf.thm	9.34186	2.148648	37.613419	1.732537	0.3	91	9.34186	2.148648	37.613419	1.732537	0.3	0.000	0.00%	0.00000	0.00%	0.00000	0.00%	0.00000	0.00%
92	TRR99_hv.thm	4.551652	2.546536	37.700272	1.732537	0.3	92	4.551652	2.546536	37.700272	1.732537	0.3	0.000	0.00%	0.00000	0.00%	0.00000	0.00%	0.00000	0.00%
93	TRR99_jf.thm	10.253266	2.140821	22.236633	1.732537	0.3	93	10.25327	2.140821	22.236633	1.732537	0.3	0.000	0.00%	0.00000	0.00%	0.00000	0.00%	0.00000	0.00%
94	TRR99_jv.thm	4.441864	2.565274	36.233765	1.732537	0.3	94	4.441864	2.565274	36.233765	1.732537	0.3	0.000	0.00%	0.00000	0.00%	0.00000	0.00%	0.00000	0.00%
95	TRR99_mr.thm	9.707772	2.346953	40.82782	1.732537	0.3	95	9.707772	2.346953	40.82782	1.732537	0.3	0.000	0.00%	0.00000	0.00%	0.00000	0.00%	0.00000	0.00%
96	TRR99_sf.thm	12.586541	2.242086	37.594925	1.732537	0.3	96	12.58654	2.242086	37.594925	1.732537	0.3	0.000	0.00%	0.00000	0.00%	0.00000	0.00%	0.00000	0.00%
97	TRR99_sv.thm	4.5553	2.554492	36.589401	1.732537	0.3	97	4.5553	2.554492	36.589401	1.732537	0.3	0.000	0.00%	0.00000	0.00%	0.00000	0.00%	0.00000	0.00%

Max

-	0.00%	-	0.00%	-	0.00%	0.000	0.00%
---	-------	---	-------	---	-------	-------	-------

Results Comparison WINDOW Version 7.4.14 to 7.4.06
Glazing Systems

3/18/2013 -- recalculated the glazing systems for 6.3.74
10/03/2015 -- calculated 7.4.06
12/09/2016 -- calculated 7.4.14

Results are identical between the two versions

GlzSys ID	IG Name	Glass Layers	Glass	emiss.	Glass / Gap / Glass layers	Glass /Gap / Glass (mm)	Gas	U-factor (W/m ² -K)				SHGC				VT			
								W7.4.06	W7.4.14	DIFF	DIFF (%)	W7.4.06	W7.4.14	DIFF	DIFF (%)	W7.4.06	W7.4.14	DIFF	DIFF (%)
1	Kawneer IGU	2	Un-Coated	0.84	5012/Air/5012	6/12.7/6	Air	2.689528	2.689528	0.00000	0.00%	0.702964	0.702964	0.000	0.00%	0.791102	0.791102	0.000	0.00%
2	No3	2	Un-Coated	0.84	103/Air/103	6/13.4/6	Air	2.681182	2.681182	0.00000	0.00%	0.704438	0.704438	0.000	0.00%	0.786104	0.786104	0.000	0.00%
3	Clr-Air-LowE_042	2	Coated #3	0.042	2004/Air/2014	6/13.4/6	Air	1.677865	1.677865	0.00000	0.00%	0.47784	0.47784	0.000	0.00%	0.697898	0.697898	0.000	0.00%
4	PFM01	2	Un-Coated	0.84	2003/Air/2003	5/16.5/5	Air	2.714314	2.714314	0.00000	0.00%	0.742617	0.742617	0.000	0.00%	0.809516	0.809516	0.000	0.00%
5	PFM02	2	Coated #2	0.11	2186/Air/2003	5/16.5/5	Air	1.853738	1.853738	0.00000	0.00%	0.624722	0.624722	0.000	0.00%	0.776382	0.776382	0.000	0.00%
6	LowE_037-Air-Clr	2	Coated #2	0.037	917/Air/102	3/15.9/3	Air	1.723422	1.723423	0.00000	0.00%	0.397977	0.397977	0.000	0.00%	0.614123	0.614123	0.000	0.00%
7	Velux FS87 Type 75	2	Coated #2	0.037	2026/Argon 95	3/9.9/3	Argon 95	2.014867	2.014867	0.00000	0.00%	0.370629	0.370629	0.000	0.00%	0.701664	0.701664	0.000	0.00%
8	TRR01	3	Coated #2,#3,#5	0.204/0.055/0.204	0907/Air/1510/Air/907	3/8.6/.1/8.6/3	Air	1.265482	1.265482	0.00000	0.00%	0.341514	0.341514	0.000	0.00%	0.535309	0.535309	0.000	0.00%
9	TRR97	2	Coated #2	0.042	2013/Air/2003	5/15.9/5	Air	1.721165	1.721165	0.00000	0.00%	0.407306	0.407306	0.000	0.00%	0.707364	0.707364	0.000	0.00%
10	TRR99	3	Coated #3,#5	0.055, 0.215	5009/Air/1510/Air/5242	3/6.2/0.1/6.2/3	Air	1.732537	1.732537	0.00000	0.00%	0.356202	0.356202	0.000	0.00%	0.582346	0.582346	0.000	0.00%
											0.00%		0.00%		0.00%				
											0.00%		0.00%		0.00%				
Max Diff											0.00%		0.00%		0.00%				

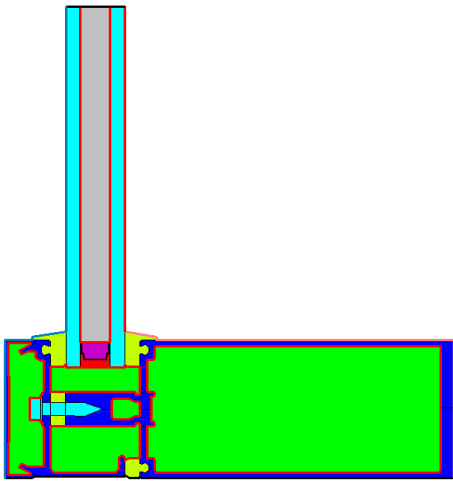

Kawneer 1600 S1

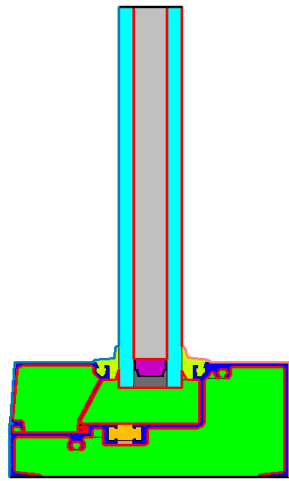

CW3

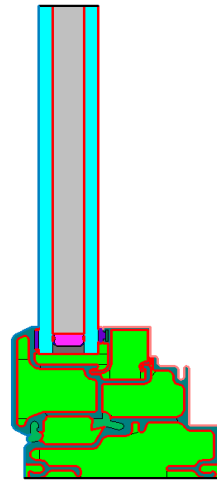

Fiberglass

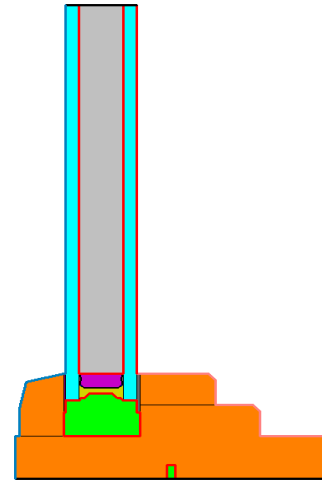

PFM

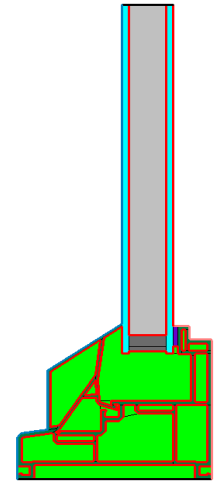

PVC

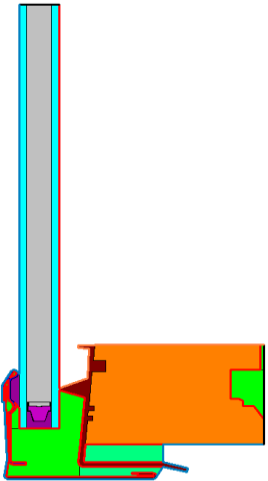

Skylight

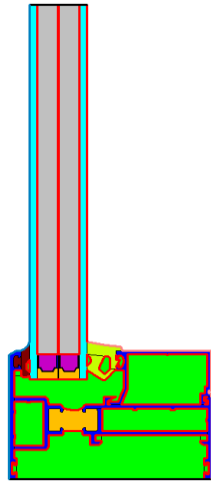

TRR01

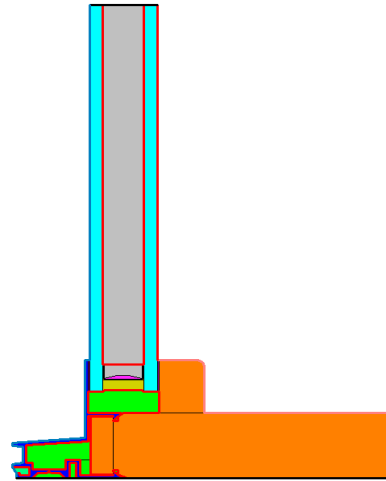

TRR97

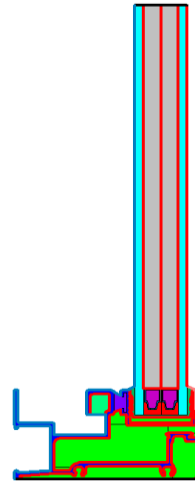

TRR99